

SANZIAGO CALATAVA



LYON AIRPORT STATION

WETTBEWERBSBEDINGUNGEN:

DER BAHNHOF SOLL EINE AUFREGENDE UND SYMBOLISCHE LANDMARKE DARSTELLEN, EIN „TOR ZUR REGION“. AUSSERDEM SOLLTE DIE NEUE BAHNSRECKE NICHT NUR LYON MIT DEM FLUGHAFEN SATOLAS VERBINDEN, SONDERN AUCH EINE ERWEITERUNG DER HOCHGESCHWINDIGKEITSSTECKE VON PARIS BIS MARSEILLE SEIN.

ENTWURFSIDEE:



-DAS MENSCHLICHE
AUGE

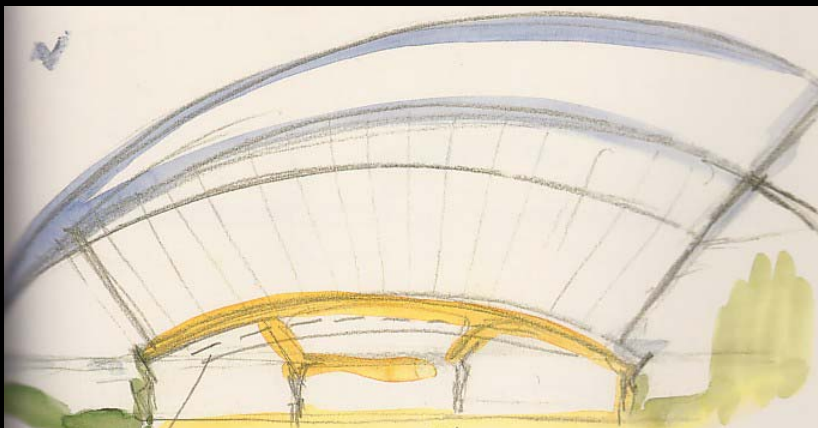



-DER VOGEL KURZ VOR DEM ABFLUG

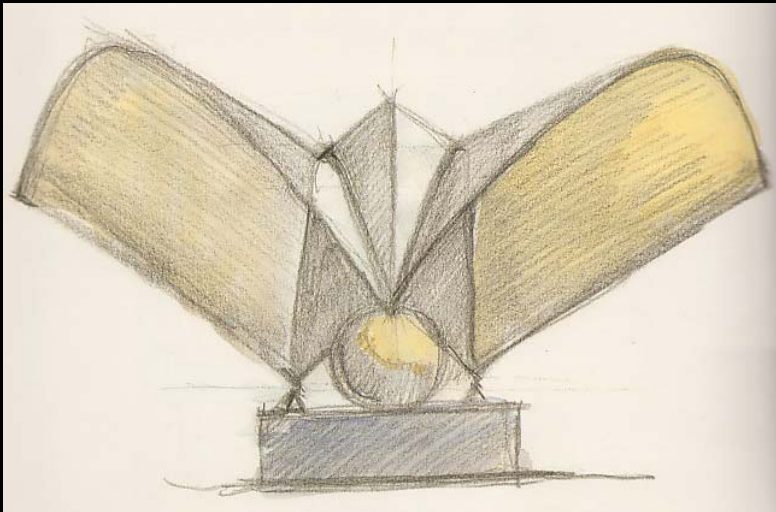



-DIE GESCHWINDIGKEIT

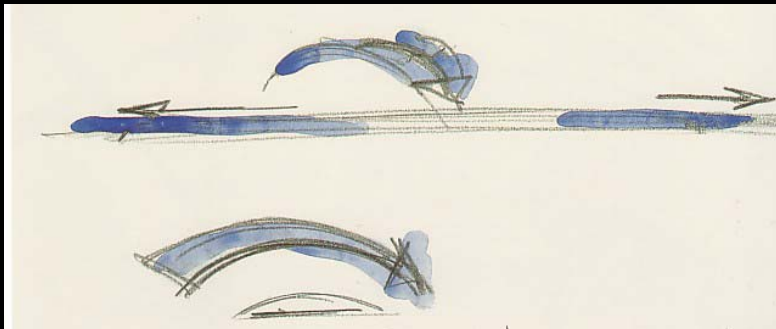

KONSTRUKTION:

-SYMETRISCHER BAU:

DIE DACHFLÄCHEN (REGELFLÄCHEN)
BALANCIEREN SICH AUS.

-DREIECKIGER GRUNDRISS:

DIE DACHFLÄCHE WIRD VON 4 BÖGEN
GETRAGEN DIE SCHEINBAR AUF EINER SEITE IN
EINEN PUNKT ZUSAMMENLAUFEN. DIE BÖGEN
SIND ÜBER 120 METER GESPANNT. DIE
ÄUSSEREN BÖGEN WERDEN ZUSÄTZLICH VON
STÜTZEN IN DER FENSTEREBENE GETRAGEN.



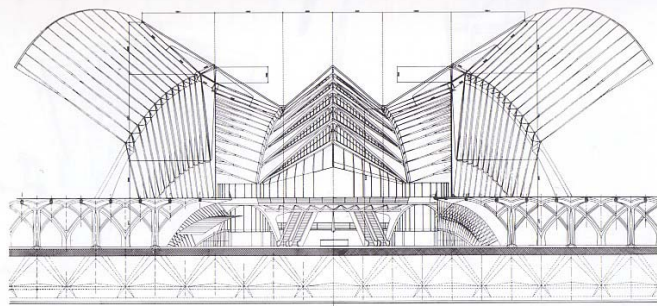

Early design, cross and longitudinal section of station hall

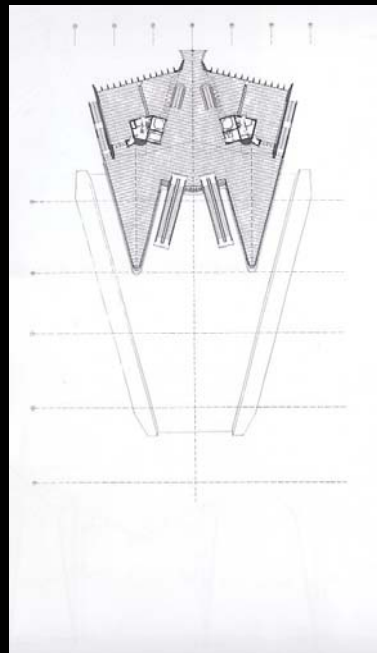
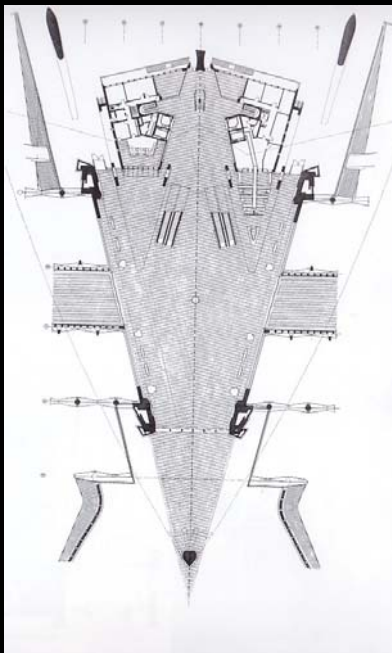
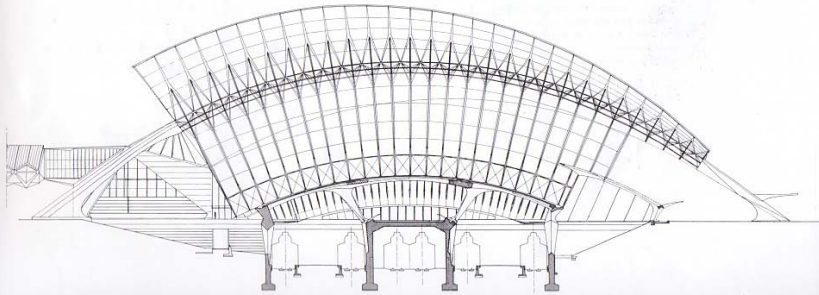

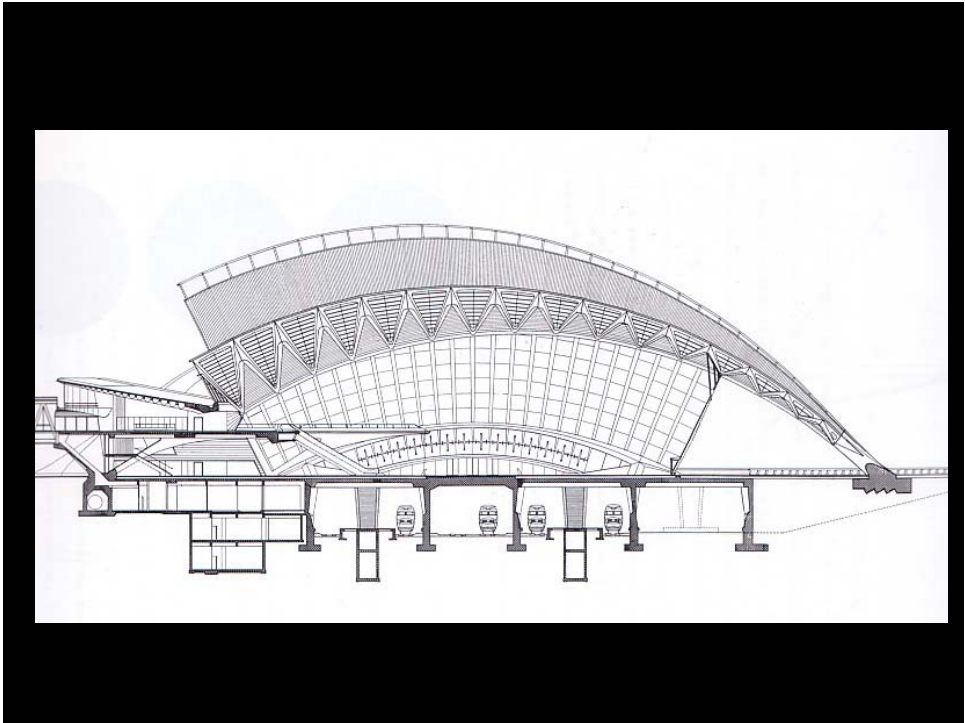



DIE REGELFLÄCHEN

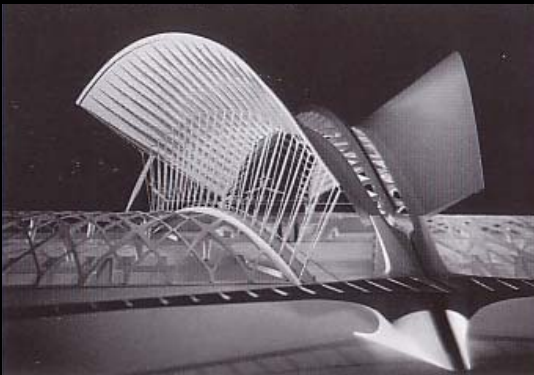
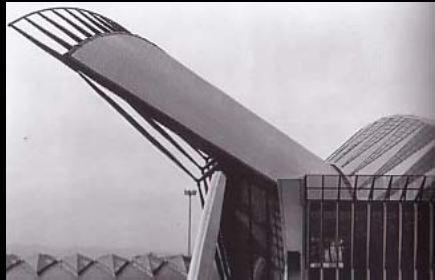

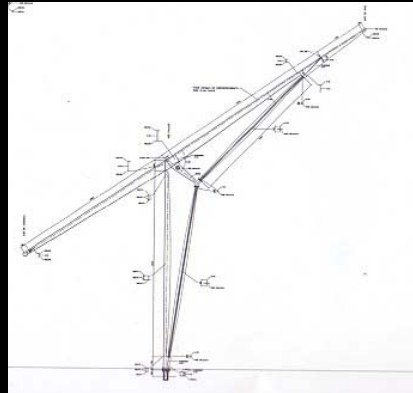
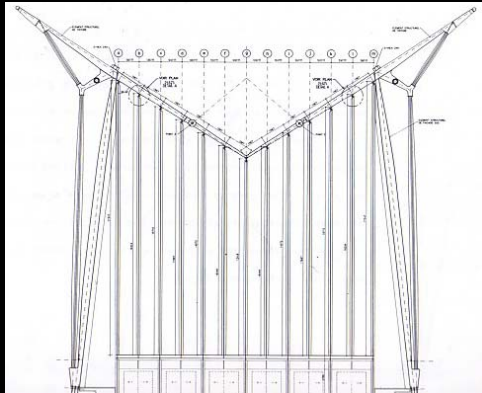

BELÜFTUNG:

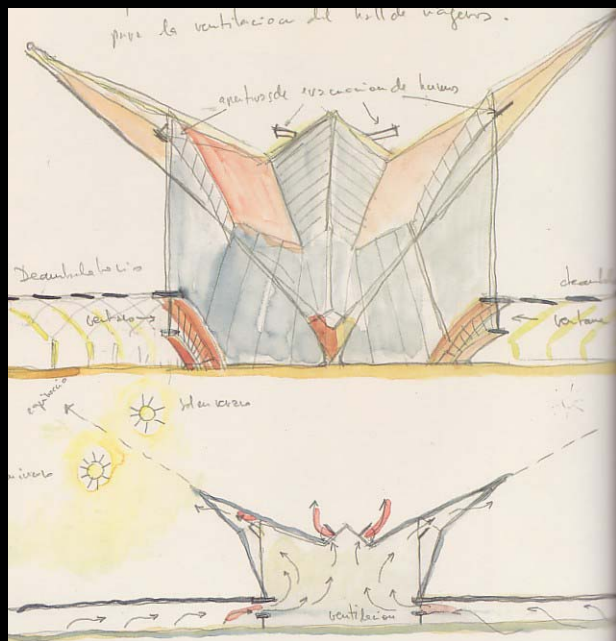

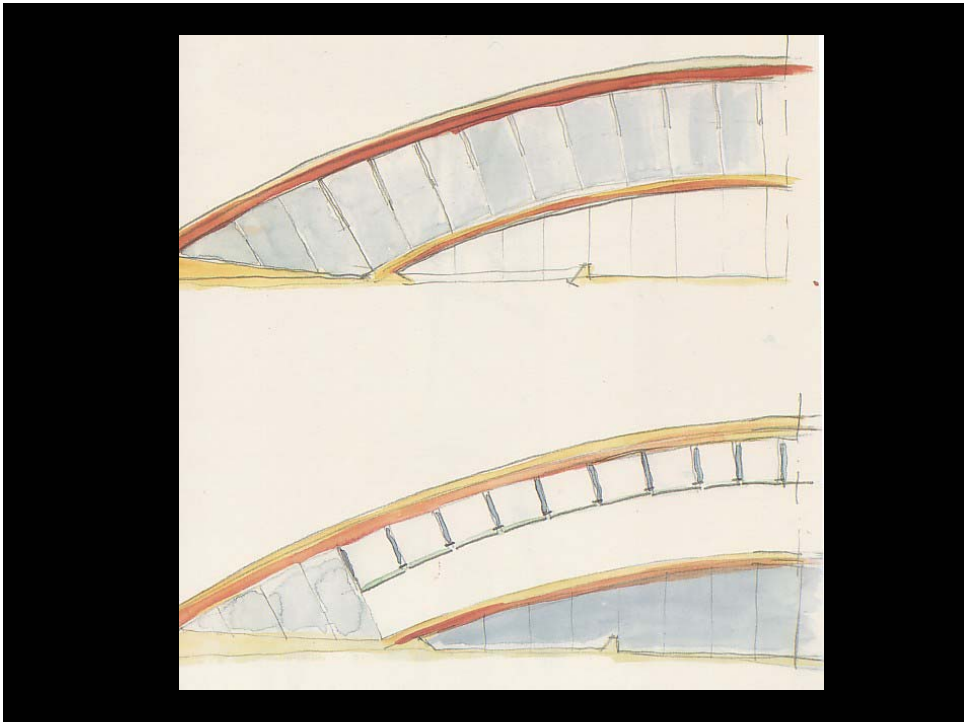
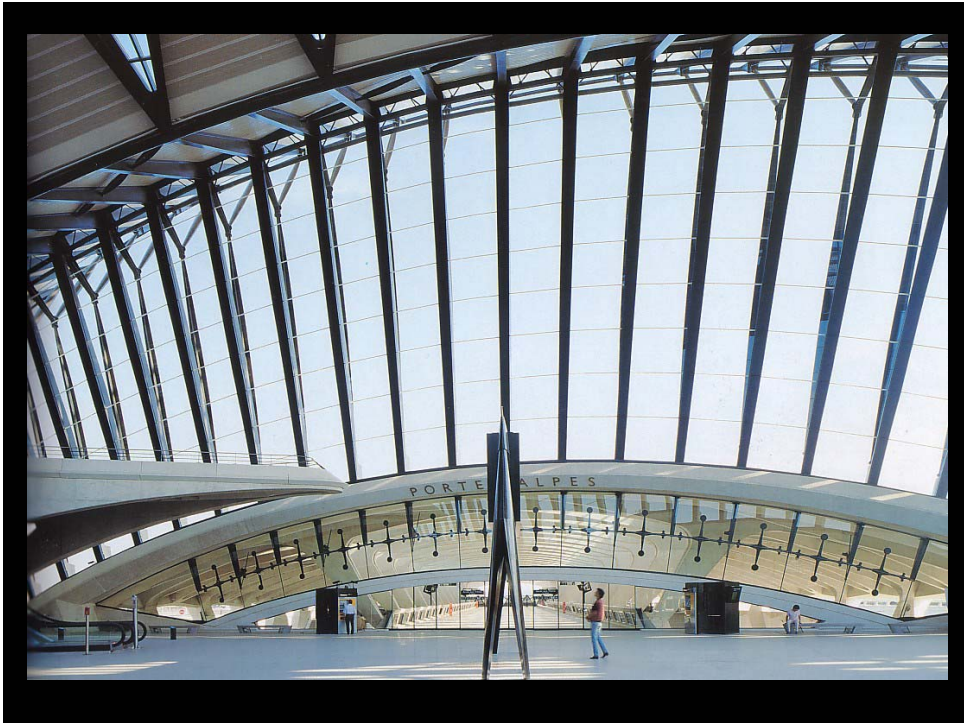

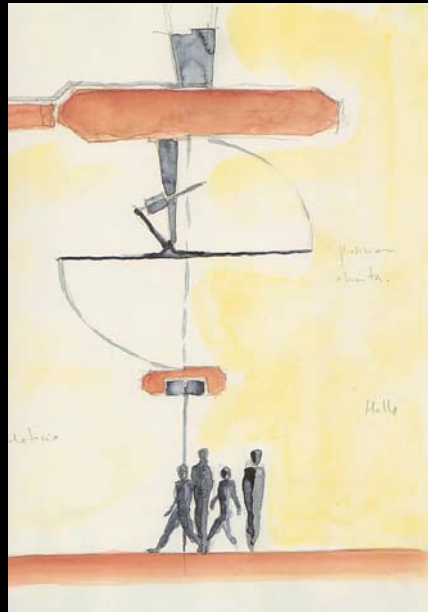
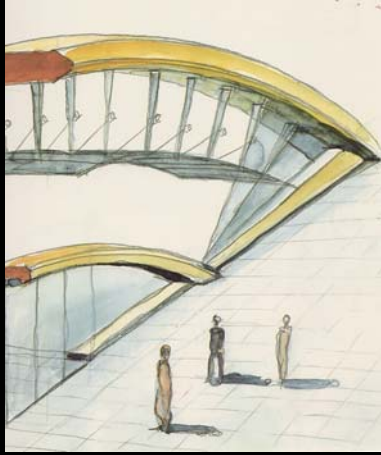

ZUR KONSTRUKTION

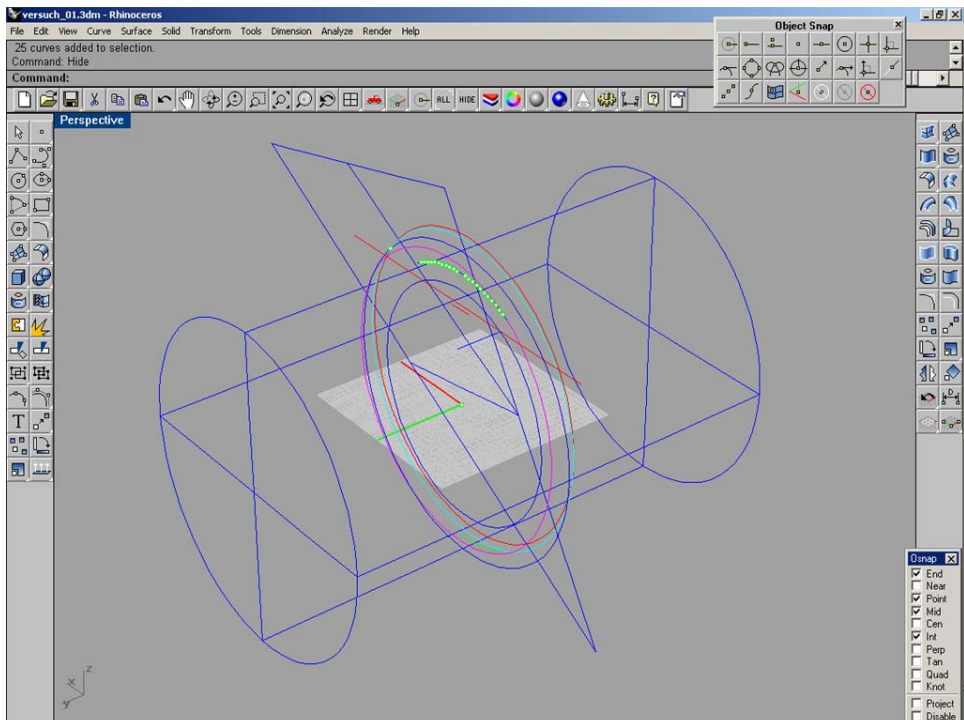

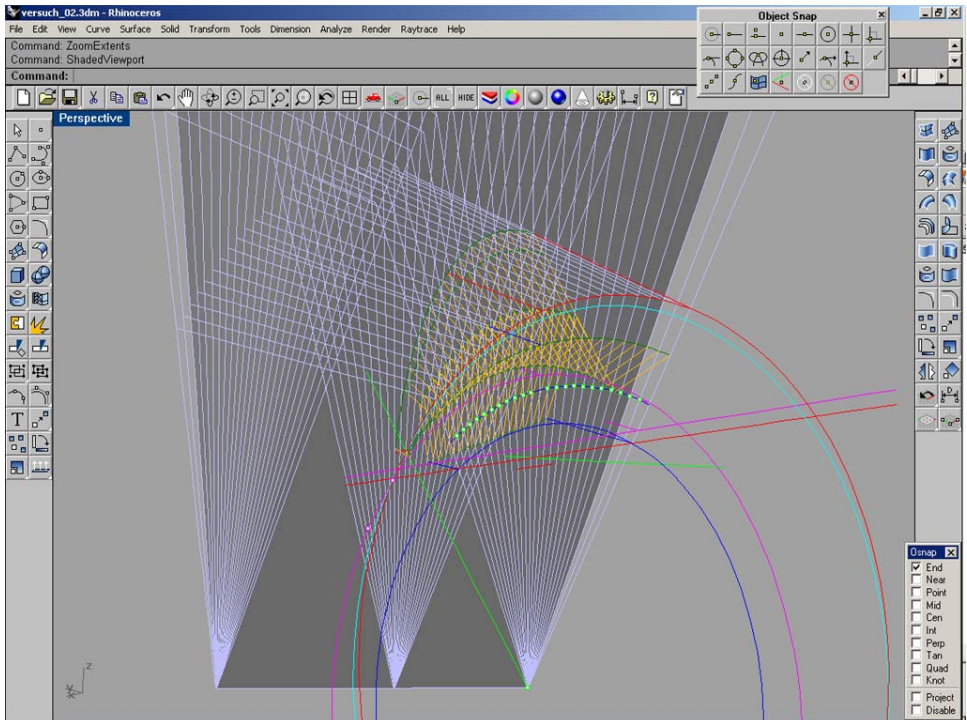
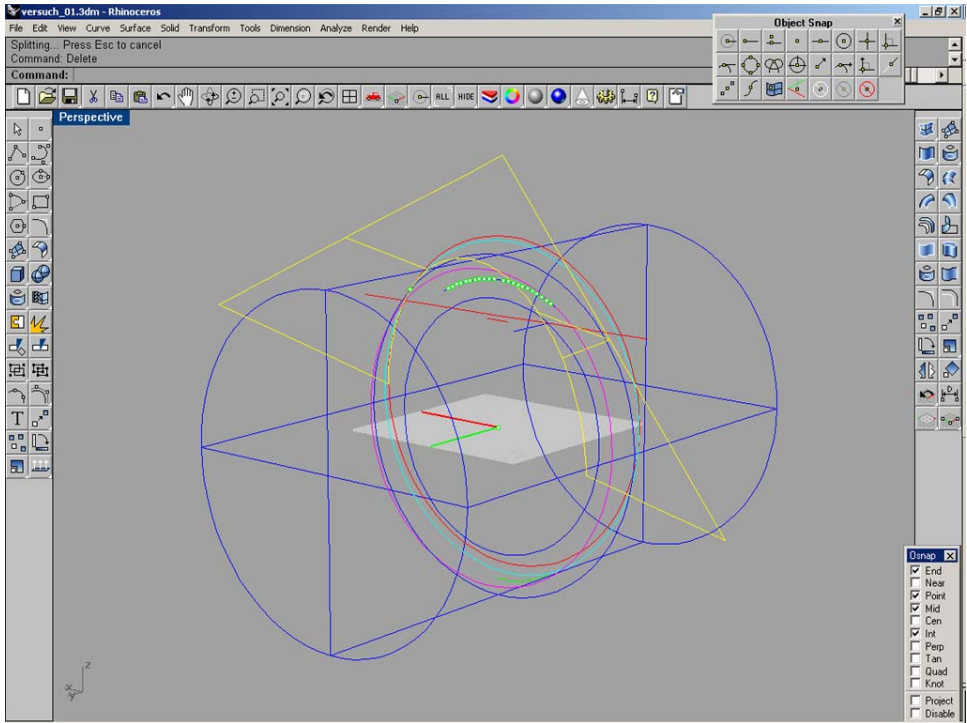

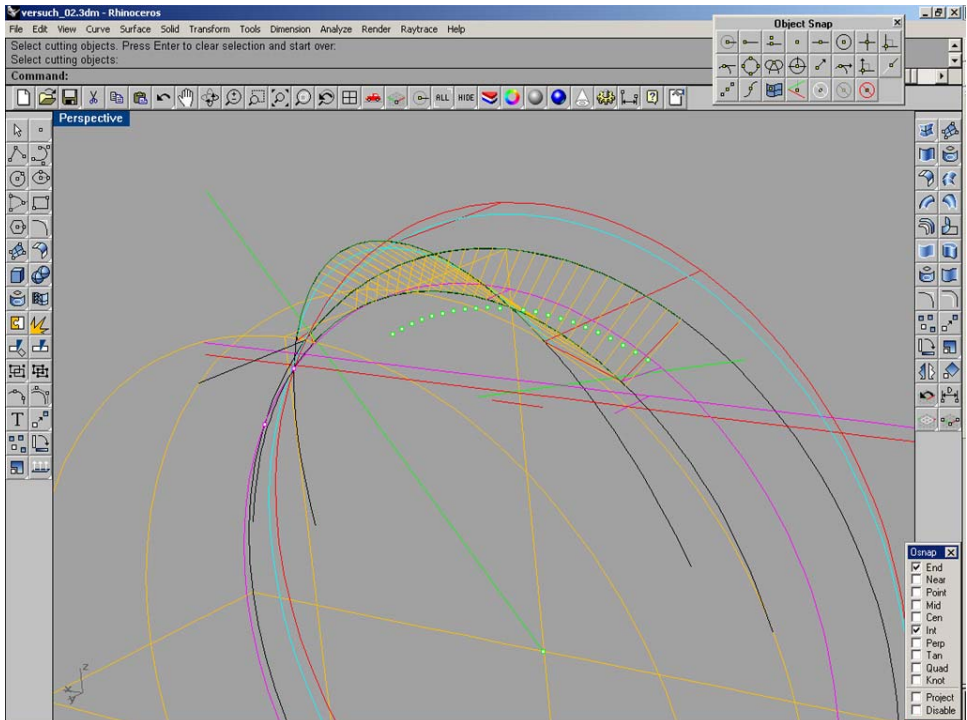
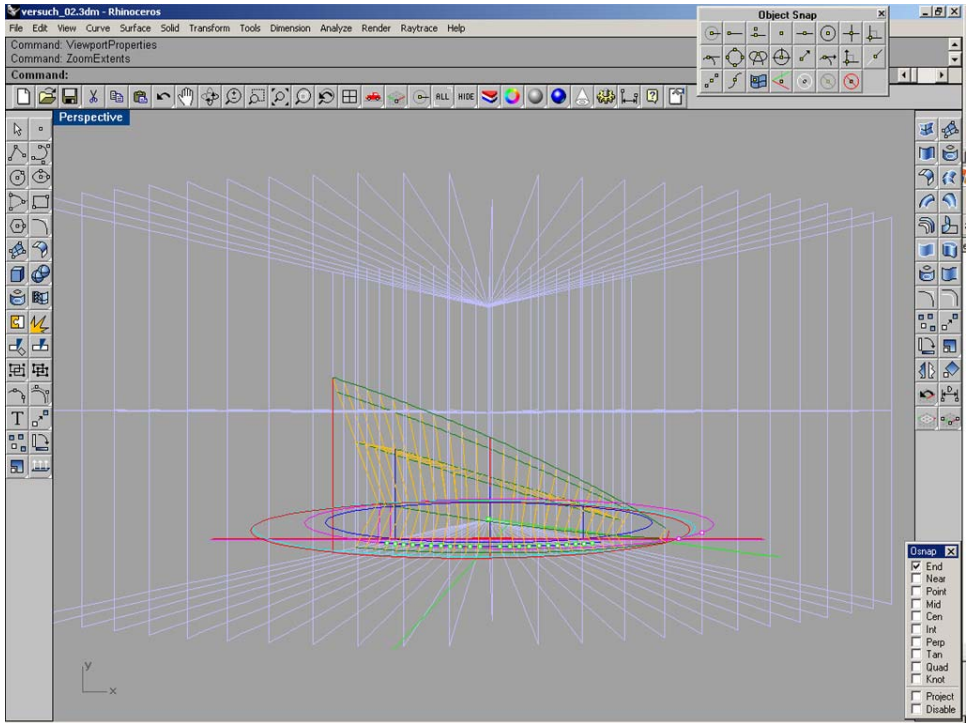

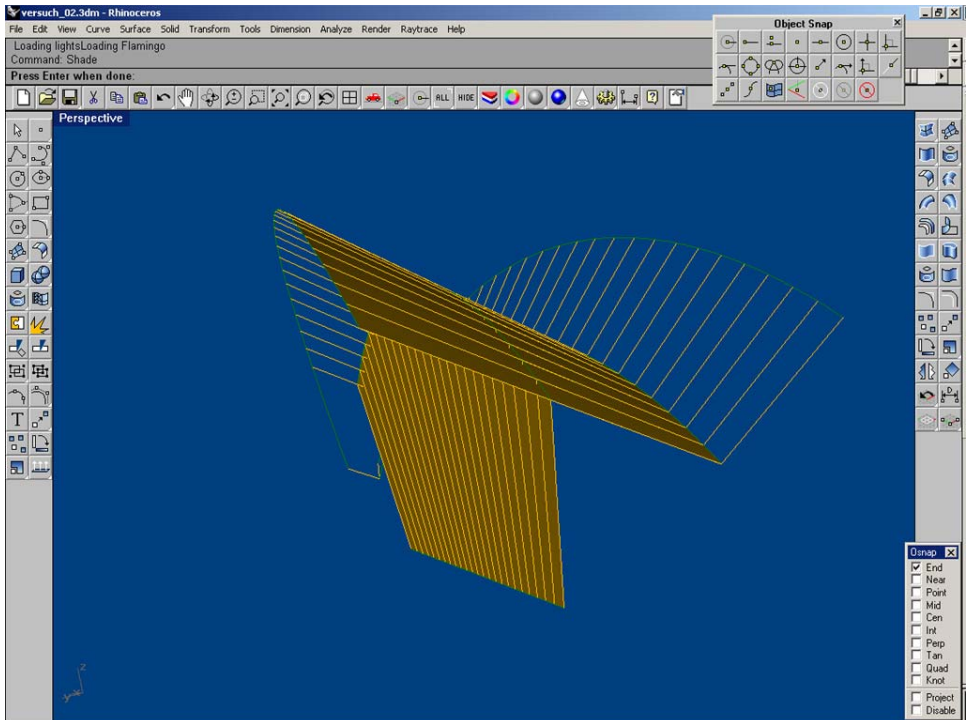
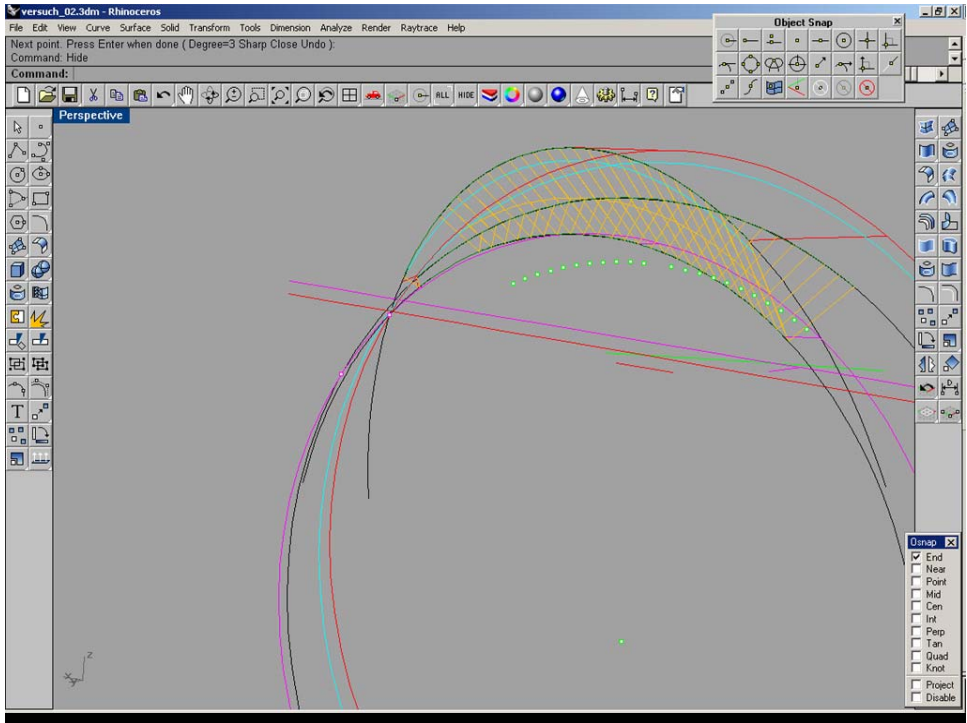

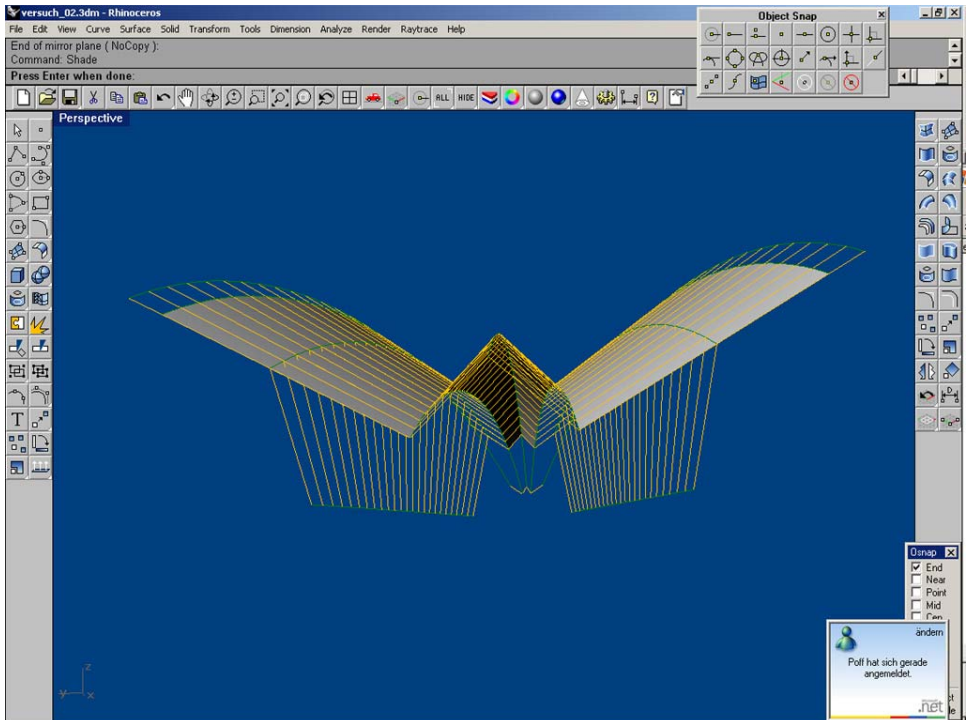
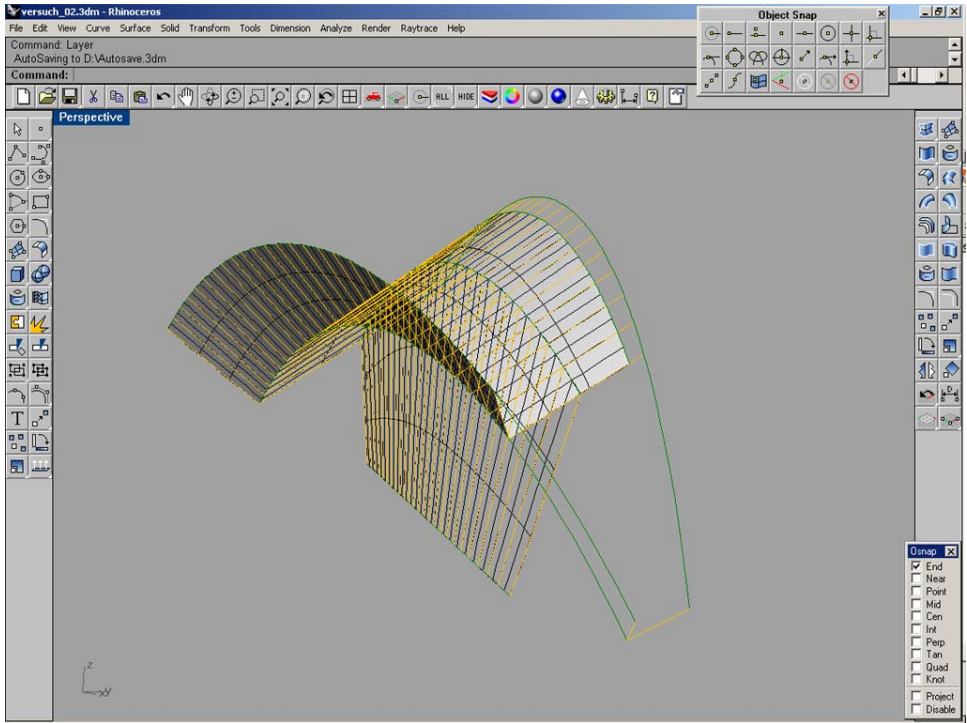

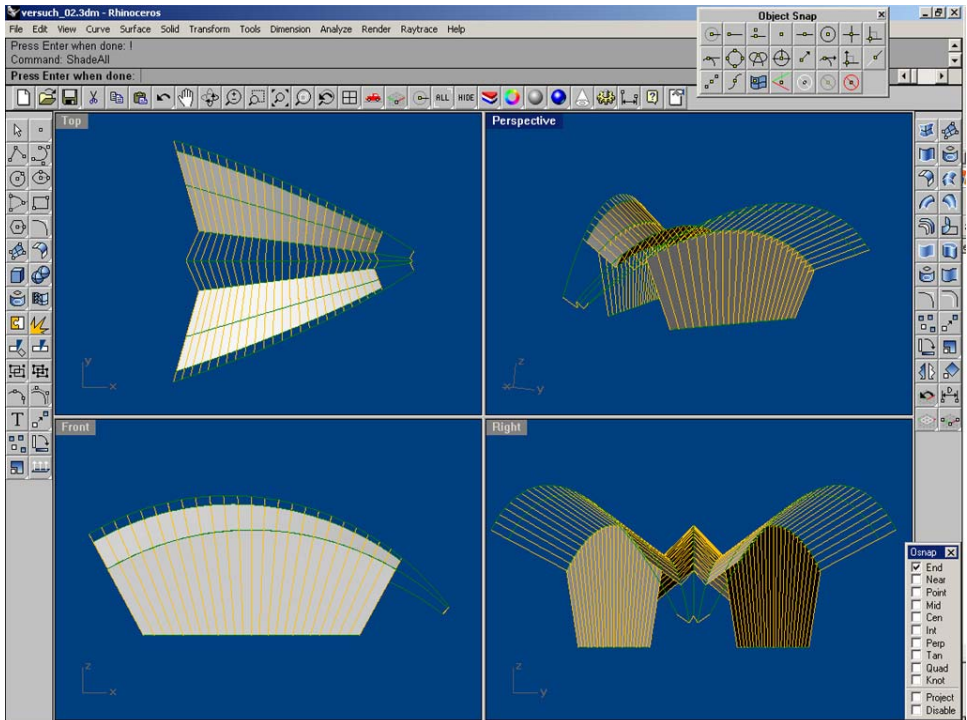
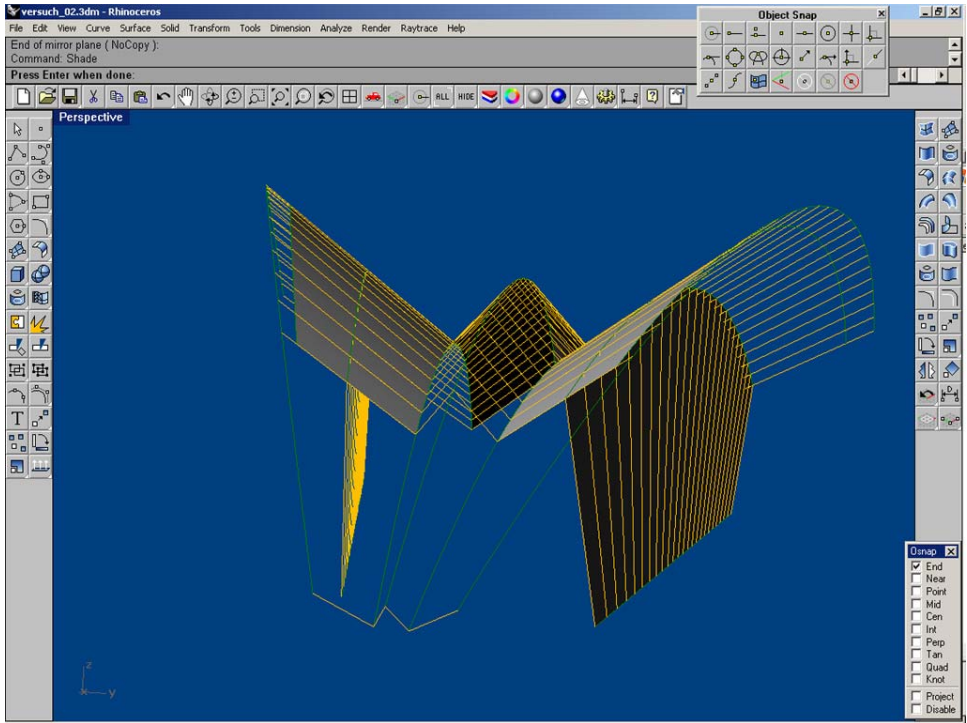

HANS-GÜNTER GABRIEL
THOMAS URTHALER
PAUL ANTON WALLNER